

A photograph of a modern dining room. In the foreground, a wooden dining table is partially visible, with several wooden chairs tucked under it. The chairs have a classic design with a curved backrest. The floor is made of wide-plank wood. In the background, there are large windows and a skylight in the ceiling, providing natural light. The overall atmosphere is bright and airy.

ASTALE

TAU

Installation Guide



CONTENTS

1 PRODUCT

2 HANDLING AND STORAGE

3 RECEPTION AND QUALITY CONTROLS

4 PRE-DESIGN RECOMMENDATIONS

5 CUTTING AND WORKING WITH THE MATERIAL

6 INSTALLATION

7 GROUTING

8 BONDING BRIDGES

9 ADHESIVES

1 PRODUCT

Introduction

The search for wellbeing in architectural spaces has been constant at TAU Cerámica all the way to achieving excellence with ASCALE. It's all-new multi-purpose, large-sized and lightweight material. TAU Cerámica is re-inventing itself and adapting architectural spaces to people's new lifestyles. The value of a brand along with work, effort, innovation and quality keep the industry alive. ASCALE strengthens the technical characteristics of top-of-the-line wall tile with more possibilities due to its lightness and adaptability.

With high pressure and temperature, we transform 100% all-natural minerals into slabs that combine natural beauty with resistance from the latest technologies.

ASCALE is large-format sintered stone that comes in 320x160 cm and is produced in three thicknesses: 6, 12 and 20 mm. ASCALE offers a great variety of 12 and 20 mm thick slabs to build any type of work surface. It also complements these thicknesses with lighter 6 mm thick slabs to clad any vertical or horizontal wall. The combination of both thicknesses, 6 and 12 mm, makes ASCALE a powerful tool for architecture, interior design and construction professionals as it allows them to create unique, elegant and versatile spaces with the unbeatable technical features of this material.

Product

Why use ASCALE? Because our sintered stone offers the ideal technical characteristics for any work surface to get the same or even better aesthetic value than with any other material.

Our collections perfectly adapt to the needs of all types of people. We have all types of marble, cement, stone, wood, metal and basic colours in our portfolio. Our mission is to create areas that evoke feelings of comfort wherever they may be.

Thanks to ASCALE, you can enjoy the most iconic natural stone finishes with the features of next-generation slabs. Moreover, our 6 and 12 mm thick slabs feature a fibreglass mesh reinforcement on the back so the material can attain the highest possible resistance.



ESTABILIDAD DIMENSIONAL
DIMENSIONAL STABILITY



IMPERMEABLE
WATERPROOF



RESISTENCIA A LA ABRASIÓN PROFUNDA
DEEP ABRASION RESISTANCE



RESISTENCIA A LA ABRASIÓN SUPERFICIAL
SURFACE ABRASION RESISTANCE



RESISTENCIA QUÍMICA
CHEMICAL RESISTANCE



RESISTENCIA A LAS MANCHAS
STAIN RESISTANCE



RESISTENCIA A LA FLEXIÓN
BEND RESISTANCE



RESISTENCIA TÉRMICA
THERMAL RESISTANCE



RESISTENCIA A LA HELADA
FROST RESISTANCE



RESISTENCIA AL CUARTEO
CRAZING RESISTANCE



RESISTENCIA AL RAYADO
SCRATCH RESISTANCE



INCOMBUSTIBLE
FIREPROOF

GAMA CROMÁTICA / CHROMATIC RANGE



LAURENT
BLACK

MACCHIA-VECHHIA
GOLD

MONTBLANC
WHITE

BAHÍA
SILVER

ARMANI
SILVER

BELVEDERE
BLACK

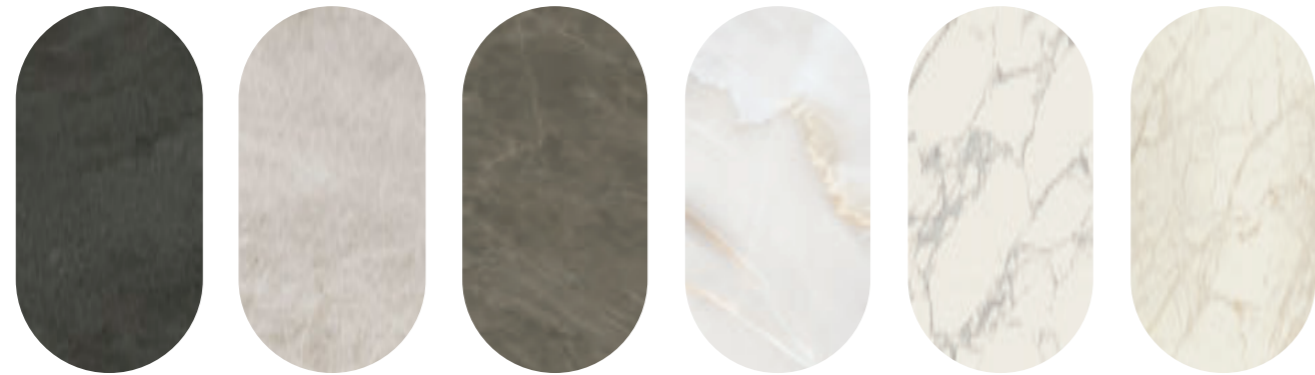

MOON
BLACK

TAJ MAHAL
ALMOND

CROTONE
PULPIS

VARESE
ONICE

TORANO
STATUARIO

VAGLI
GOLD



LABRADORITE
ROYALBLUE

ARABESCATTO
WHITE

ALLURE
BLACK

PALOMASTONE
LINEN

CARDOSO
GRAY

TIVOLI
WHITE

GAMA CROMÁTICA / CHROMATIC RANGE



GRASSI
WHITE

DUCAL
GOLD

MARQUINA
BLACK

ALTO
STATUARIO

BORGOGNA
SILVER

ARIZONA
SAND



COSMOPOLITA
IVORY

COSMOPOLITA
SILVER

COSMOPOLITA
GRAY

LASCA
WHITE

BOREAL
SAND / UMBER

MOMA
RUSTEEL

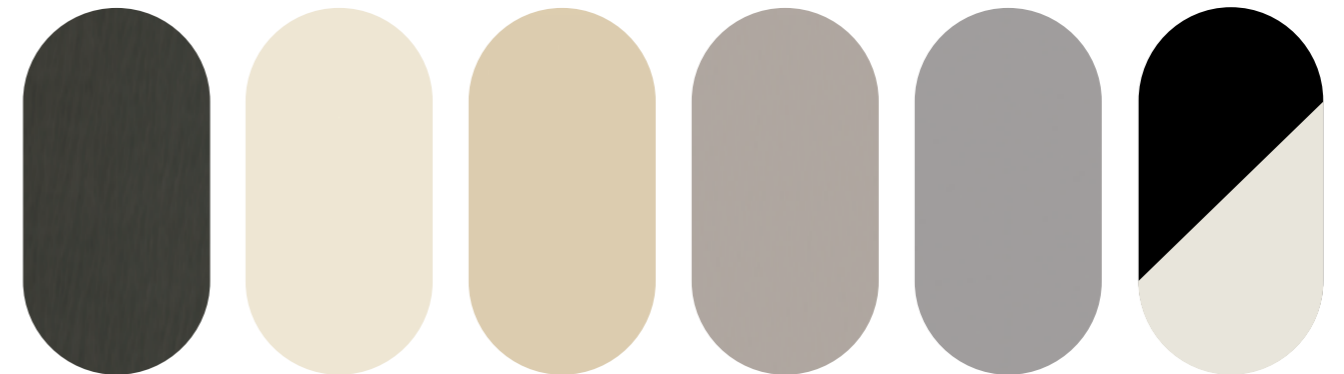

ETNA
BLACK

CROMIA
WHITE

CROMIA
IVORY

CROMIA
SILVER

CROMIA
GRAY

ALPI WHITE
CROMIA BLACK

ACABADOS / FINISHES

MATT

SOFT MATT

POLISHED



ESPEJOR / THICKNESS



ACABADOS / FINISHES



MATT



SOFT MATT



PULIDO / POLISHED

FORMATO / FORMAT

126" x 63"
320 x 160

APLICACIÓN / APPLICATION



REVESTIMIENTO:
Tanto interior como exterior.
FACHADAS.
PAVIMENTO:
Tanto interior como exterior
MOBILIARIO.

WALL TILE
Interior and outdoor.
FAÇADES.
FLOORING:
Interior and outdoor
FURNITURE.

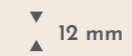

ENCIMERAS:
Para baño y cocina.
PAVIMENTO:
exterior.

COUNTERTOPS:
Kitchen and bath.
FLOORING:
Outdoor.



ENCIMERAS:
Para baño y cocina.
PAVIMENTO:
exterior.

COUNTERTOPS:
Kitchen and bath.
FLOORING:
Outdoor.



| CHARACTERISTIC CARACTERÍSTICA | STANDARD NORMA DE ENSAYO | DETERMINATION DETERMINACIÓN | AVERAGE VALUE VALOR MEDIO | |
|--|--------------------------------|---|--|---|
| Weight Peso | | Weight / m ² Peso por m ² | 6 mm+ 14.95 kg/m ² | |
| | | | 12 mm+ 29.86 kg/m ² | |
| | | | 20 mm 49.75 kg/m ² | |
| Dimensional and surface features Características dimensionales y superficiales | ISO 10545-2 | Slab weight Peso de una tabla | 6 mm+ 76.3 kg | |
| | | | 12 mm+ 152.9 kg | |
| | | | 20 mm 254.9 kg | |
| Water absorption Absorción del agua | ISO 10545-3 | Acceptable deviation: Average thickness Desviación admisible: Grosor medio | ±5% | |
| | | | Flatness Planitud | ±0.35% |
| | | | Surface quality Calidad de la superficie | >95% free of visible flaws (Compliant) >95% Libre de defectos (Conforme) |
| Impact resistance Resistencia al impacto | ISO 10545-5 | Coefficient of restitution Coeficiente de restitución | 6 mm+ 0.8 | |
| | | | 12 mm+ 0.91 | |
| Deep abrasion resistance Resistencia a la abrasión profunda | ISO 10545-6 | | Average value 140 mm ³ Valor medio mm ³ | |
| Linear thermal expansion Dilatación térmica lineal | ISO 10545-8 | | <7.0 x 10 ⁻⁶ °C ⁻¹ | |
| Thermal shock resistance Resistencia al choque térmico | ISO 10545-9 | | Resists Resiste | |
| Moisture expansion Dilatación a la humedad | ISO 10545-10 | | 0.01% (0.1 mm) | |
| Frost resistance Resistencia a la helada | ISO 10545-12 | | Resists Resiste | |
| Chemical resistance Resistencia química | ISO 10545-13 | Acids and bases Ácidos y bases | Matt/Soft MATT Mate: Class ULA- ULB Polished Pulido: Class 3-4 | |
| | | Cleaning products and pool reagents Productos de limpieza y reactivos de piscinas | Class UA Clase UA | |
| Stain resistance Resistencia a las manchas | ISO 10545-14 | | Matt/Soft MATT Mate: Class 5 Polished Pulido: Class 3-4 | |
| Cadmium and lead release in mg/ dm ² Cesión de cadmio y plomo en mg/ dm ² | ISO 10545-15 | | Compliant Conforme | |
| Colour fastness Resistencia de los colores a la luz | DIN 51094 | | | |
| Static load for raised floors Carga estática en pavimentos elevados | EN ISO 12825 | Average values Valores medios | | |
| Volatile organic compounds emitted Emisión de compuestos orgánicos volátiles | EN ISO 16000-9 | Emission test chamber method Método de ensayo de emisión de cámara | | |
| Cold liquid resistance Resistencia a líquidos fríos | EN 12720 | Furniture - Assessment of surface resistance to cold liquids Mobiliario. Evaluación de la resistencia de la superficie a los líquidos fríos | | |
| Wet heat resistance Resistencia al calor húmedo | EN 12721 | Furniture - Assessment of surface resistance to wet heat Mobiliario. Evaluación de la resistencia de la superficie al calor húmedo | | |
| Dry heat resistance Resistencia al calor seco | EN 12722 | Furniture - Assessment of surface resistance Mobiliario. Evaluación de la resistencia de la superficie al calor seco | | |
| Bend resistance Resistencia a la flexión | ISO 10545-4 | Breaking strength Fuerza de rotura | 6 mm+ 1556 N * | |
| | | | 12 mm+ 5500 N ** | |
| | | | 20 mm 14000 N * | |
| | | Modulus of rupture Módulo de rotura | 6 mm+ 54.5 N/mm ² * | |
| | | | 12 mm+ 53 N/mm ² ** | |
| | | | 20 mm 52 N/mm ² ** | |

2 HANDLING AND STORAGE

Weights / Dimensions

| Technical information | U.M. | 6 mm | 12 mm | 20 mm |
|---|----------------|-------------------|--------|-------|
| Slab surface | m ² | 5.12 | 5.12 | 5.12 |
| Slab weight | kg | 76 | 149 | 253 |
| Weight per m ² | kg | 15 | 29 | 49 |
| Slabs per trestle* | nr. | 44 | 22 | 12 |
| Net m ² per trestle | m ² | 225.28 | 112.64 | 61.44 |
| Metal trestle weight | kg | 210 | | |
| Full trestle weight | kg | 3589 | 3377 | 3221 |
| Dimensions of trestle including packaging | mm | 3300 x 750 x 1900 | | |

Slab handling

Transport with clamps

It's the best way to move 12 and 20 mm thick ASCALE slabs. Always pay attention to the movement and handling of the slabs to prevent splintering or breakage. ASCALE recommends using the following type of clamp for lifting and moving individual slabs:

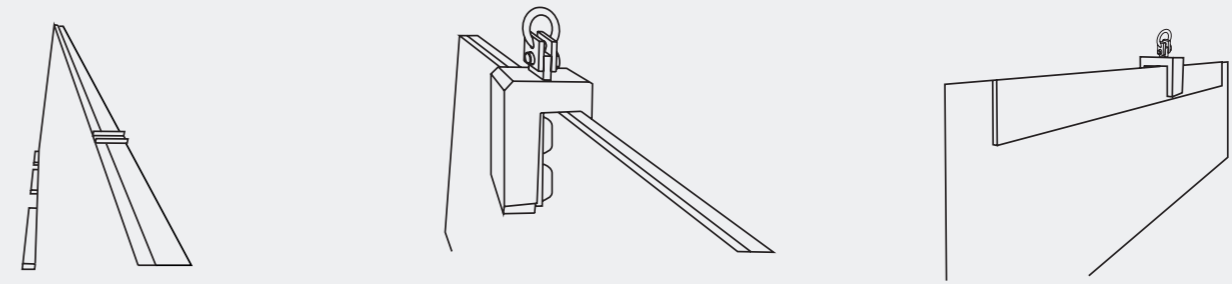

The additional width of this clamp will prevent the slab from bending during handling to, thus, prevent undesirable breakage.

Recommendations:

- Clamping more than 2 slabs at the same time is not recommended.
- Make sure to cover all metal surfaces that may come into contact with the slab with adhesive foam tape.

If this type of clamp is not available, use a 2 cm thick plank of approximately 3 m x 20 cm so the clamp can catch 12 mm slabs.

Fixing the ends of the slab with jacks to the plank so the slab doesn't sag during handling is recommended.

Position the plank to the rear of the slab to be lifted.

- 1) Place the clamp on the slab and plank.
- 2) Fix the clamp and lift the slab and plank with care.
- 3) Avoid sudden changes in direction.

Transport with slings

An adequate system for moving several slabs at the same time. Using canvas slings is recommended.

Metal slings must not be used to handle ASCALE slabs. Using wooden spacers is recommended to prevent direct contact between the slings and slabs.

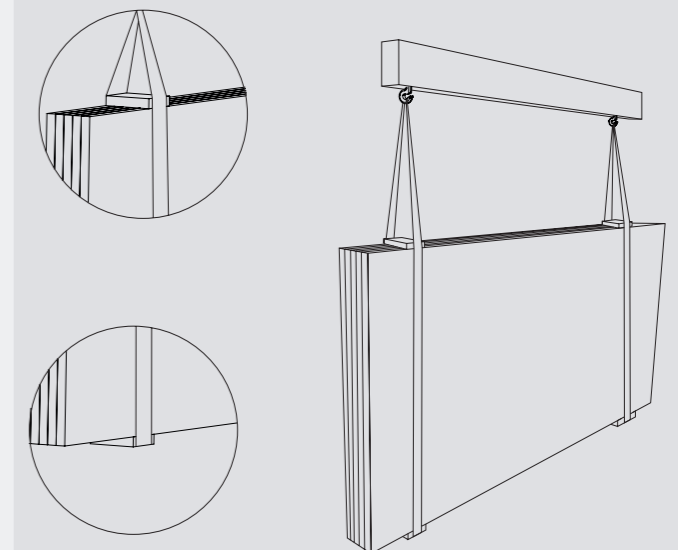

Manual transport

Always keep in mind the weight of anything that needs to be transported. Get help from any type of support and never move slabs in a flat horizontal position as this may cause excessive buckling.

✘ INCORRECT

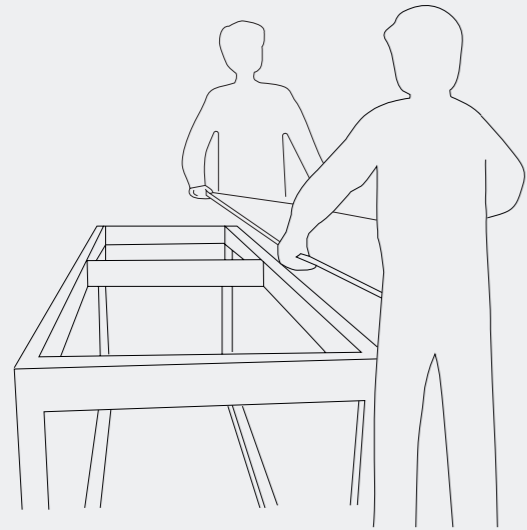

✘ INCORRECT

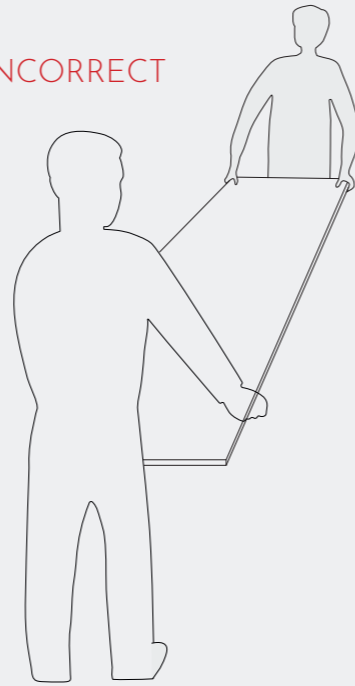

✔ CORRECT

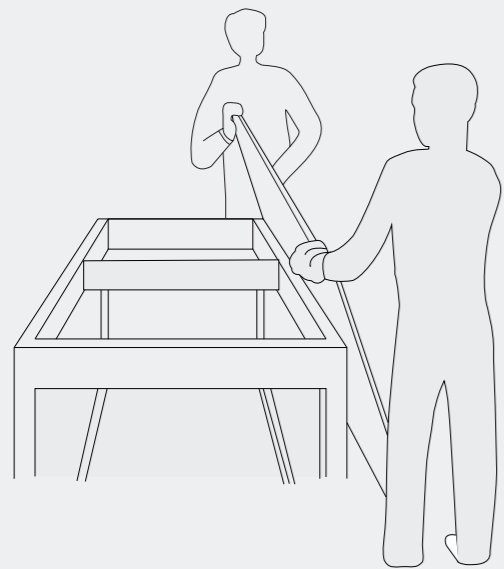

✔ CORRECT

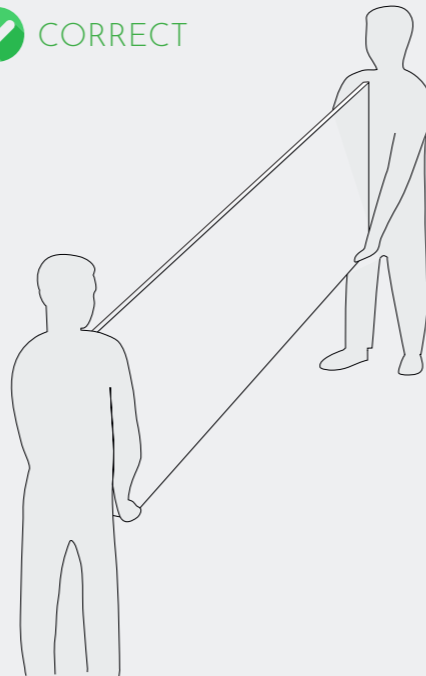

Transport using a frame with suction cups

This is only recommended for 6 mm thick slabs. The suction cups may be placed all along the frame to adapt to the size of the piece to be moved. Using this tool is also recommended when installing the slab in its final location.

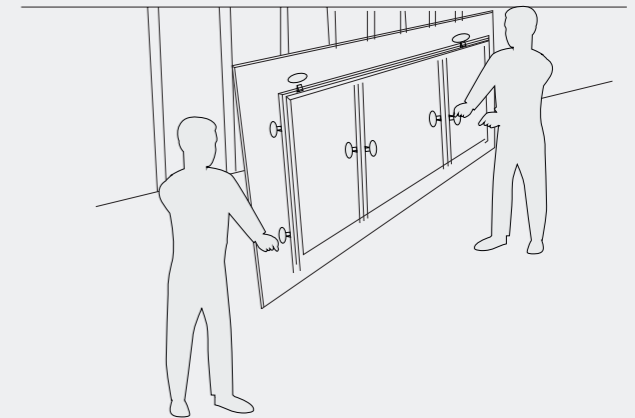
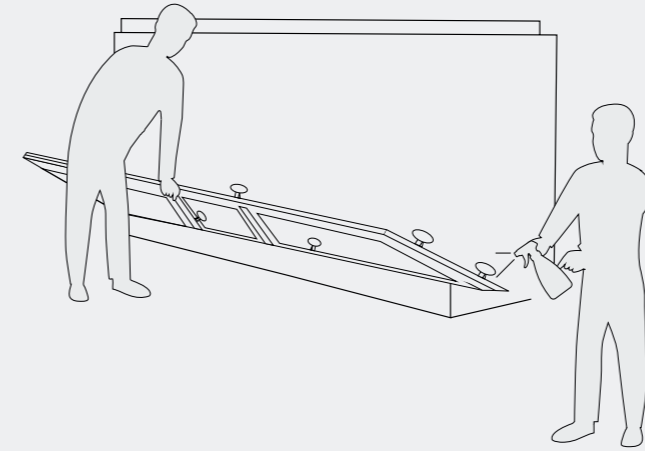
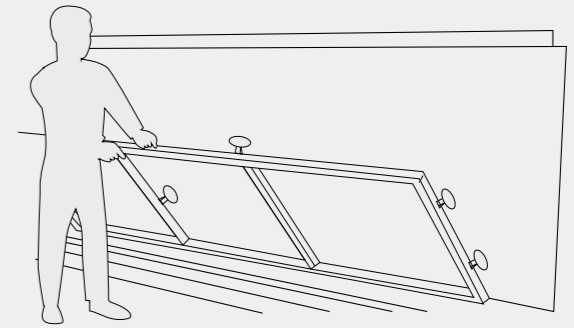

If this type of frame is not available, an aluminium rod or similar element, secured with several jacks, can also be used. This will prevent the piece from bending too much during handling.

Fixing thin, long pieces (skirting, for example) with jacks to an aluminium rod for transport is also recommended.

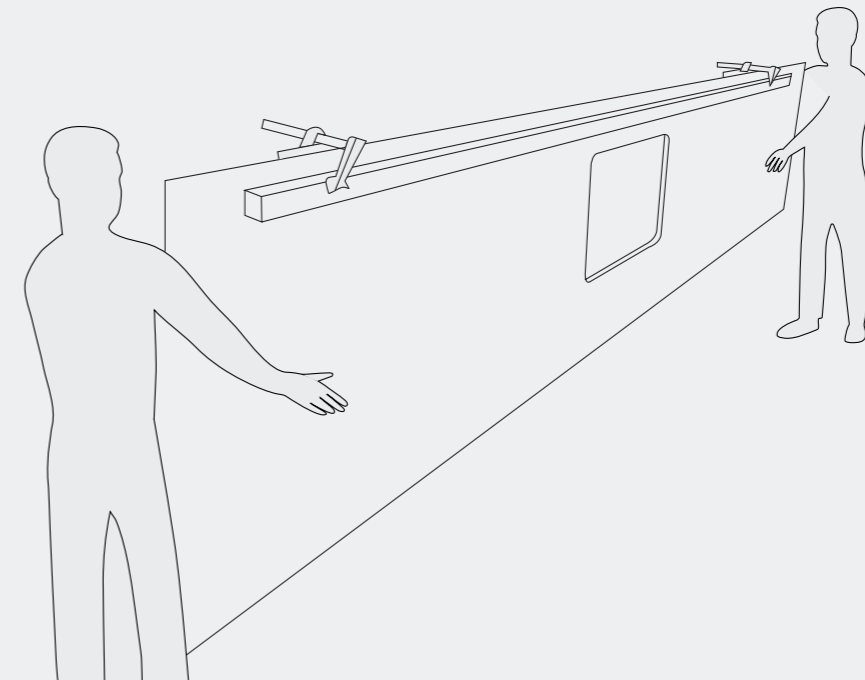

Packing

After production, the slabs are placed on trestles which are ideal for transport and storage after proper labelling.



Trestles with ASCALE slabs must be loaded, unloaded and moved using a proper lift truck, crane or other handling mechanism.

Whenever handling or moving, make sure the load is balanced.

If possible, keep your ASCALE slabs on the same trestle they came on. Any subsequent handling must be by using adequate trestles or rails (wooden or metal) with proper protection to vertically support the slabs (wooden, plastic or rubber) to prevent chips and dents at the support point.

Storage

When storing slabs on trestles not supplied by us, using a continuous support base or at least one with four support points for the slabs is recommended. This base must be rigid (preferably made of wood). This will prevent splintering on the edges of the ASCALE slabs.

Make sure the ASCALE slabs have at least three support points (one in the middle and two on the sides).

If storing in the open air, cover the slabs with waterproof fabric.

The cut pieces may have sharp edges, so handle with care and adequate protection.

Cut material must be packaged with cardboard or similar protection on the corners and with shock absorbance panels on the perimeter edges (in adequate thicknesses) as protection against blows.

If the product is not packaged adequately, it may break.

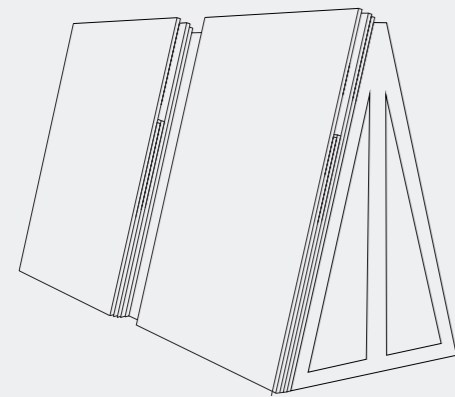
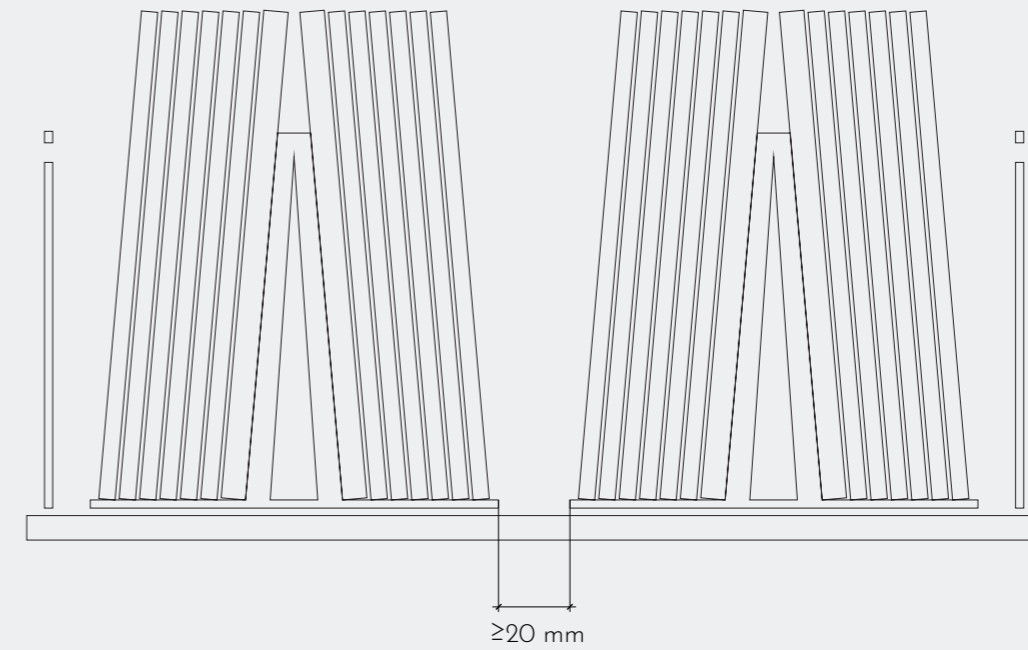

✘ INCORRECT

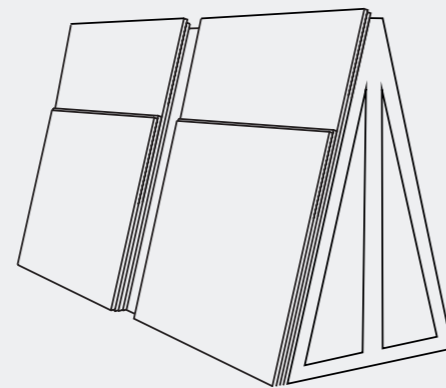

✔ CORRECT

"Avoid positioning large slabs against smaller slabs:"

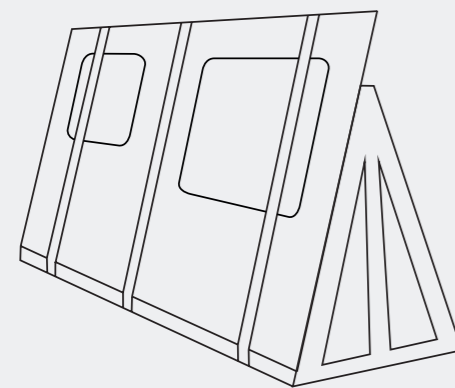

✘ INCORRECT

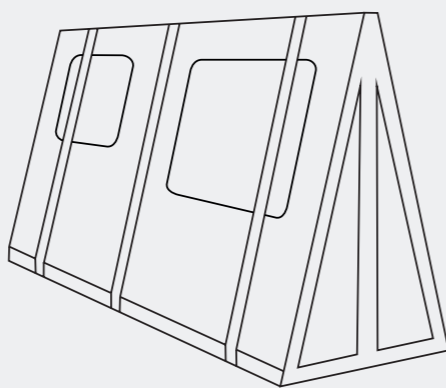

✔ CORRECT

"Likewise, check that the trestle or base on which the slabs are supported is larger than the slab surface:"



3 RECEPTION AND QUALITY CONTROLS

ASCALE controls the slabs in accordance with the highest standards of quality. Even still, always inspect the material received before starting any work by following these steps:

- Check the outside of the packaging (no visible blows or damages).
- Check that everything corresponds between the transport document, order and material received. The product code is printed on the side edges of each slab.

- Visually inspect the slabs for possible surface defects: fissures, stains, colour fading, variations in shine and imperfections. An inspection against the light is highly recommended.

No claims will be accepted for installed or manufactured material when defects were already present upon delivery of the material. Marble workers are responsible for determining whether the slabs are adequate for use. If they are not adequate, the supplier must be contacted immediately so they may be exchanged before the slabs are cut or modified in any way.

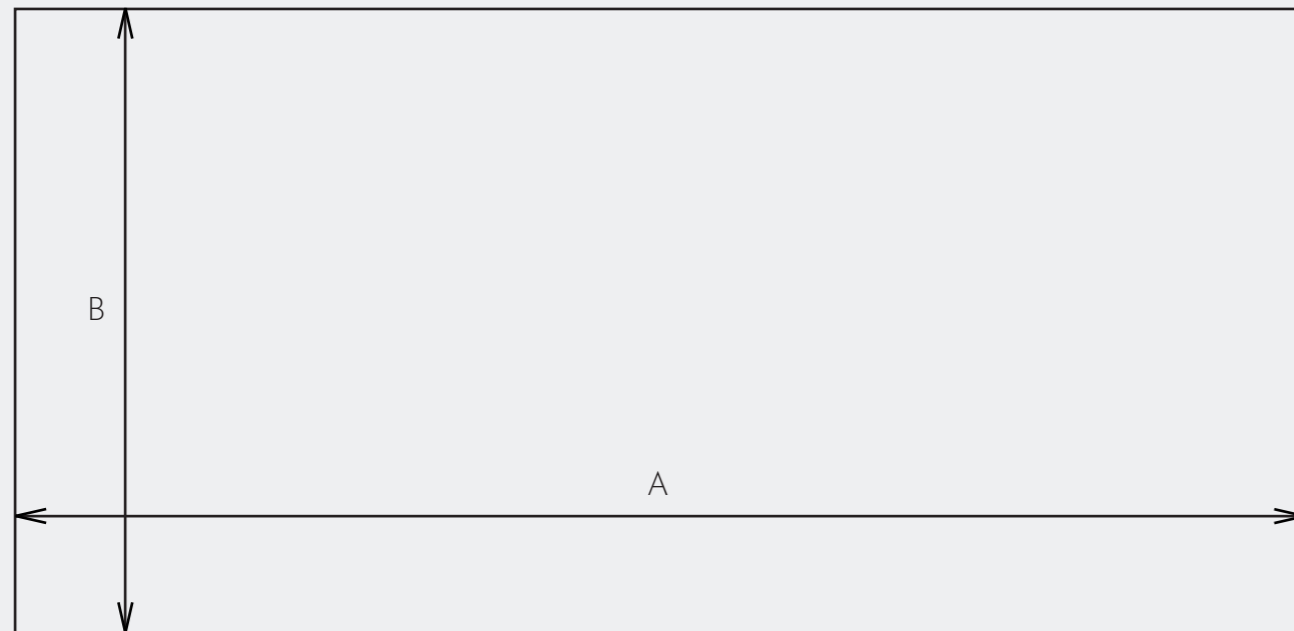
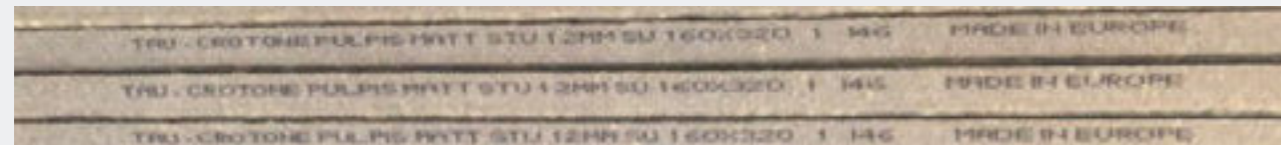

| Dimensions | Length mm (A) | Width mm (B) |
|-------------------|---------------|--------------|
| For guidance only | 3240 | 1630 |
| Useful for 6 mm | 3197 | 1597 |
| Useful for 12 mm | 3200 | 1600 |
| Useful for 20 mm | 3200 | 1600 |

Flatness

To check the flatness of a slab, position it over a completely flat horizontal base free of any residue.

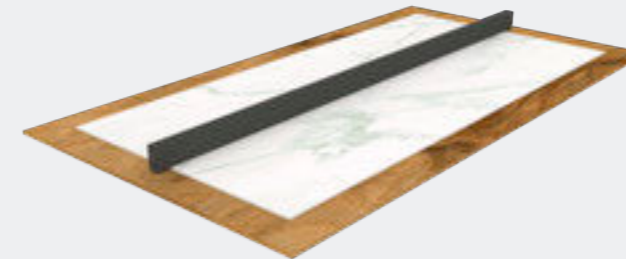

Maximum slab width tolerance: 2 mm
Maximum slab length tolerance: 4 mm

Slab identification

Each slab is affixed with a label indicating important information to ensure their traceability such as the model, tone and production date. Keep or record the label for future reference.



4 PRE-DESIGN RECOMMENDATIONS

Workspace: evaluating the logistics of the job is important as the installation of slabs with dimensions of 3200 x 1600 mm requires enough space for handling and installation.

Layout: due to the flatness, Ascale slabs may be installed following any diagram, even staggered with the seams offset by 50%.

L-cuts: avoid them whenever possible; use on surfaces with the smallest slabs or by adding seams. In fact, the supports and plaster at these points transmit stress and building settlement over time which can cause the

material to crack due to weakening caused by the irregular cut. This phenomenon is not considered a material defect.

Material planning: when using large-size slabs, check the installation diagram and final formats to be installed to verify the quantity of material needed for the wall or floor tiling. Always have extra material in case something breaks during the process or for future needs.

5 CUTTING AND WORKING WITH THE MATERIAL

Ascale slabs may be easily cut and perforated.

The most complicated cutting, profiling and hole-making operations can be done at specialist shops and centres with a disc saw, digital control machine, water jet cutter or other professional equipment available. See the Ascale "Countertop Technical Manual" for recommendations.

The easiest work with the material may be done directly on site. Use care when moving pieces and cutting. They can be used for dry and wet systems which are also used for glass, natural stone and porcelain tile. This means there is no problem with adjusting panel dimensions on site or making special cuts, holes, boxes, etc.

Rectilinear manual cuts

Normally used to adjust slab dimensions. Ascale 6 mm+ slabs are supplied rectified and squared which makes the work on site much easier.

The most common method is with dry glass cutters. This system is appropriate for making 6 mm+ tiles:

1. Mark the intended cutting line.
2. Secure the cutting rod over the visible side of the tile, firmly securing it and making sure the incision wheel is just over the cutting line marked.
3. Make a pre-incision in each one of the ends, 1-2 cm from the inside to the outside of the tile.
4. Make a complete incision from one end to the other without stopping and with a constant cutting speed and constant pressure.
5. Move the tile over the work bench, making sure the incision line exceeds the bench by 10-15 cm.
6. The slab will be almost cut already. Separate both sides of the cut with the clamps. Two people should do this together when the cut tile format is large.
7. Cut the reinforcement mesh with a cutter.
8. Remove any sharp edges, bevelling with diamond discs or abrasive sandpaper.



Non-rectilinear manual cuts

Trace the cutting line with a pencil. Use a grinder with diamond bits to cut the tile. Making these types of cuts on site is recommended only when working on small jobs.

Perforations

Position the tile over a flat, stable surface. Begin making the hole with a diamond crown bit with an angle of approx. 75° with respect to the slab.

Make the hole by carefully swaying the tool, making sure the cutter constantly cools down.

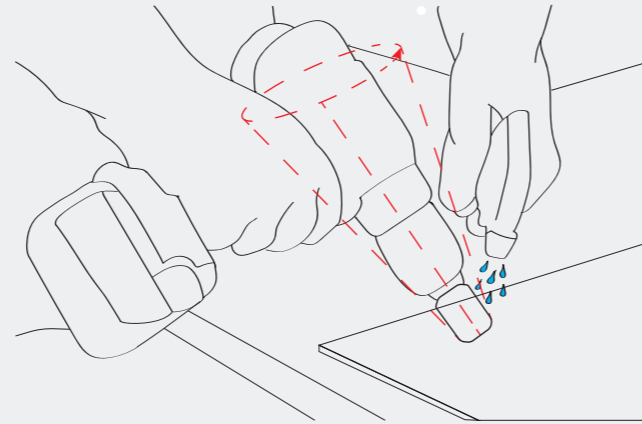

L-cuts and boxing

These are critical points. Doing them correctly will prevent breakage and cracking.

Leave a radius of more than 3 mm in any inner L-cut. The bigger the radius, the stronger the piece will be. For these points, also respect the corresponding seams indicated on the successive points.

Position the tile over a flat, clean and stable work surface.

The holes for electrical sockets must be opened at a minimum distance of 5 cm from the tile edges. Once the hole measurements are delineated, begin perforating on the visible side of the tile. Make drill holes (without the hammer mode) with diamond cutters (diam. 6-10 mm), swaying the drill and making sure the tool is constantly cooled with water.

Make the holes in the four corners. To open the hole, make straight cuts between the holes with a diamond disc cutter with a small diameter.

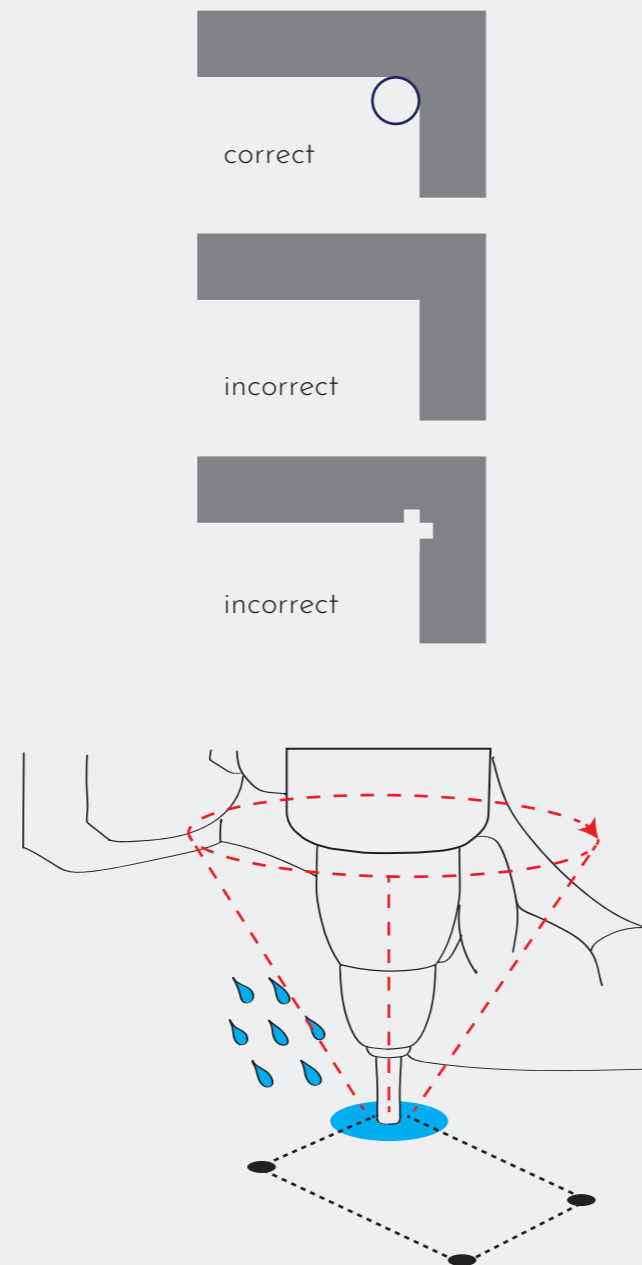

6 INSTALLATION

Preliminary considerations

The support on which the slab will be installed is of vital importance to proper installation and proper functioning of the wall tile over time. Before beginning the installation, check that the support has these characteristics:

- It is dry and the surface is free of paint, grease, resin, dust and, in general, any loose particle.
- It is compact and has the mechanical resistance required for the intended use.
- It is stable after completely setting and settling. There must not be any cracking. For unstable supports and floor slabs or any with light fissures, using an anti-fracture mesh between the support and the tiling is recommended.
- It is flat. To install large-format Ascale slabs, fill in the level differences using adequate levelling products.
- It has been made with the necessary perimeter and expansion joints.

Applying adhesive

Handling Ascale slabs with suction frames will be necessary in most cases. Check that the suction cups are tight before moving the slabs. Cleaning and dampening the suction cups before attaching them increases the attachment to Ascale slabs.

To apply fast-drying cement, position the slab fixed to the suction cup frame, rotating the slab facing down. A flat work bench will be required where the frame can rest without deforming or arching the slab.

Once the slab is secured in a horizontal, flat position, the back of the slab must be cleaned to remove any dirt that may affect the adhesive adherence.

Double gluing

Adhesive must be applied using the double gluing technique; in other words, on the back of the Ascale slab and on the support.

Using a 3-4 mm flat notched trowel on the back of the slab is recommended. Then, use a 10 mm slanted notched trowel with the support. Try to cover all corners and edges and avoid air pockets between the support and the piece of slab.

Position the slab in the desired location and hit the slab with a rubber hammer to remove all encapsulated air between the layers of adhesive.

For best results, extend the adhesive on the tile and on the support with the trowels in the same direction, preferentially parallel to the shortest side of the slab to make it easier to get all air out when hitting with the hammer.

Double gluing is necessary so the tension caused by support expansion and movement is evenly distributed over a larger area.



Joints

Ascale slabs in 6 mm thickness are supplied rectified. Added to the low thermal expansion in the material, this means thick joints between pieces and at meeting points with other construction elements are not necessary. Even still, the installation of joints is necessary to prevent breakage or unsticking due to the behaviour of the support. There are several types of joints:



Legend

Grey: Installation joints

Blue: Expansion joints

Red: Perimeter joints

Grout lines or installation joints

Or the habitual joints between two Ascale pieces. Necessary to absorb the tension transmitted to the wall tile and spread the steam in the lower strata of the system. They must be 2-3 mm thick in interiors and at least 5 mm thick outdoors, whenever the support is stable.

Expansion or area joints

Joints that only affect the wall tiling, designed to divide the total area to be tiled into smaller regular sub-areas to absorb the expansion and contraction of Ascale tiles. For indoor floor tiling, they must be at least 5 mm thick and delimit a maximum area of 40 m². For outdoor floor tiling, they must be at least 8 mm thick and delimit a maximum area of 12 m².

Expansion joints must also be used in door passages and thresholds, coinciding with the floor slab joint. Even in contiguous rooms where there is a change in flooring, different tensions may arise in the floor slab. Therefore, an expansion joint is necessary.

Perimeter joints

Necessary for changes in plane and in the perimeter boundaries of the areas to be tiled; they minimise the transmission of tension between different construction elements that work together. For flooring, these joints affect the wall tiling as well as the thickness of the mortar expansion while they may only affect the wall tiling on walls. In any case, any perimeter joints must be at least 8 mm thick.

Structural joints

They're the ones in the building structure which not only cross through the structure but also the rest of the layers of the system (wall tiling, adhesives, insulation layers and decoupling layers, etc.) meaning they must also be respected with Ascale slabs. They must normally be finished off with a metal profile or elastic sealant.

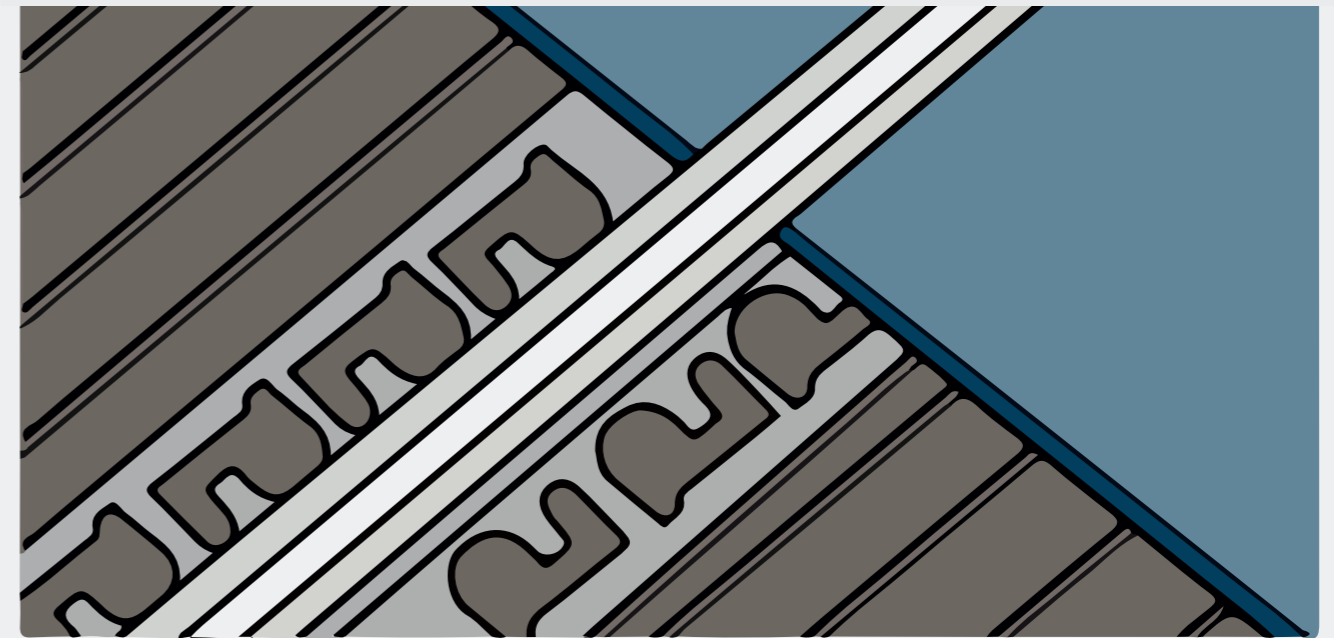
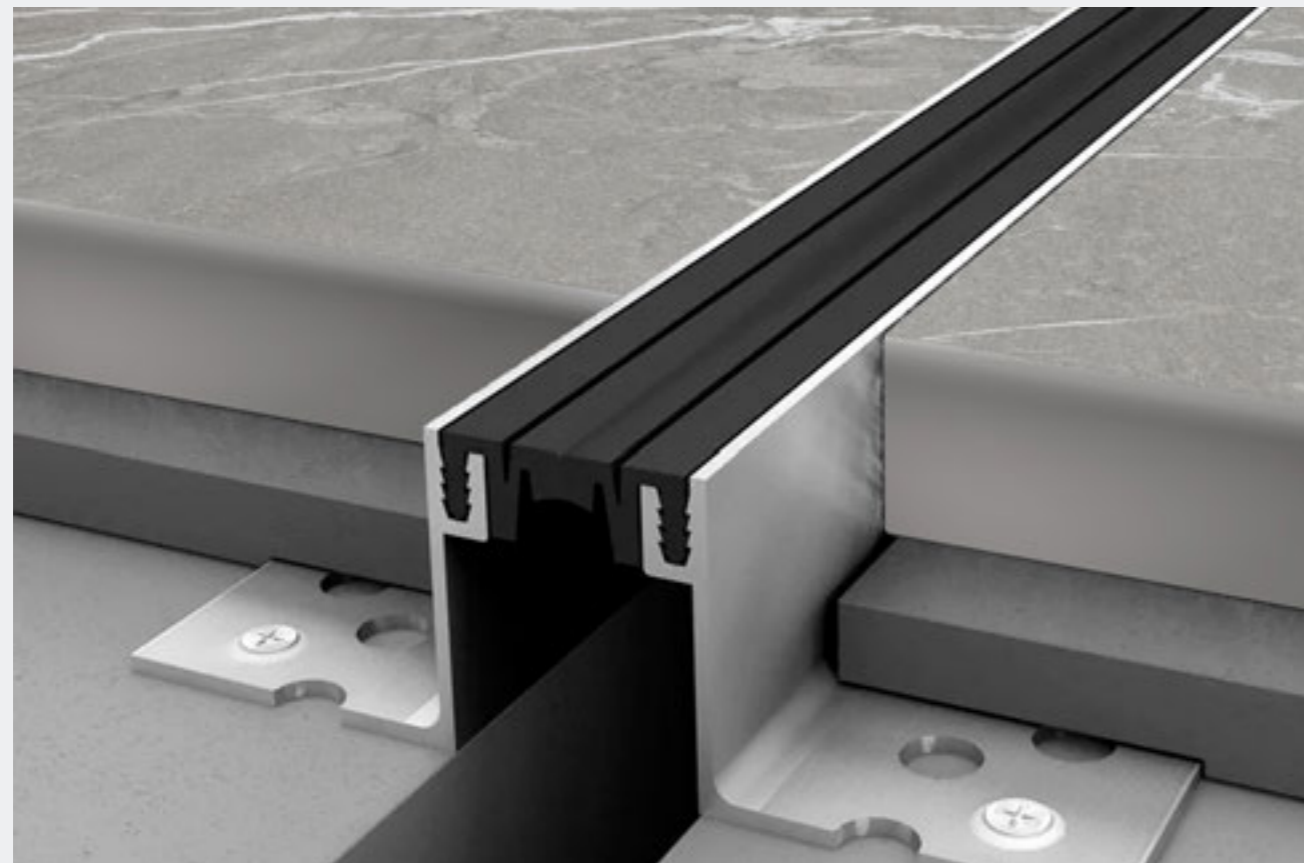

Levelling systems

They are of special importance for large-format tiling to get completely flat and even finishes. There are several advantages to these systems:

- They help achieve levelled floor tiling
- They ensure the ASCALE slabs are firm against the support
- They reduce the slab installation time



Levelling process:

1. Install the levelling supports: once the adhesive is spread, place the plastic supports under the piece all along the sides of the piece. For large-size pieces, more than one support per side is recommended.
2. Position the floor tile and insert the wedges in the support groove, being careful not to break them. Now, you can check the exact levelness of the floor tile with a level. If not correct, adjust by putting pressure on it with the corresponding wedges.
3. Let the adhesive completely set and remove the supports, separating the part that sticks out of the base with a slight crosswise blow.

7 GROUTING

Grouting material is no less important when installing floor tiling which may end up ruining a good installation otherwise both aesthetically or functionally.

The choice of grout depends on the conditions to which it will be exposed:

- Mechanical characteristics: adherence, deformability, resistance to traction, compression and bending
- Material behaviour: water absorption, steam diffusion capacity, resistance to abrasion, fire, frost/thawing cycles
- Surface characteristics: uniform colour and texture, chemical resistance, stain resistance, mould resistance

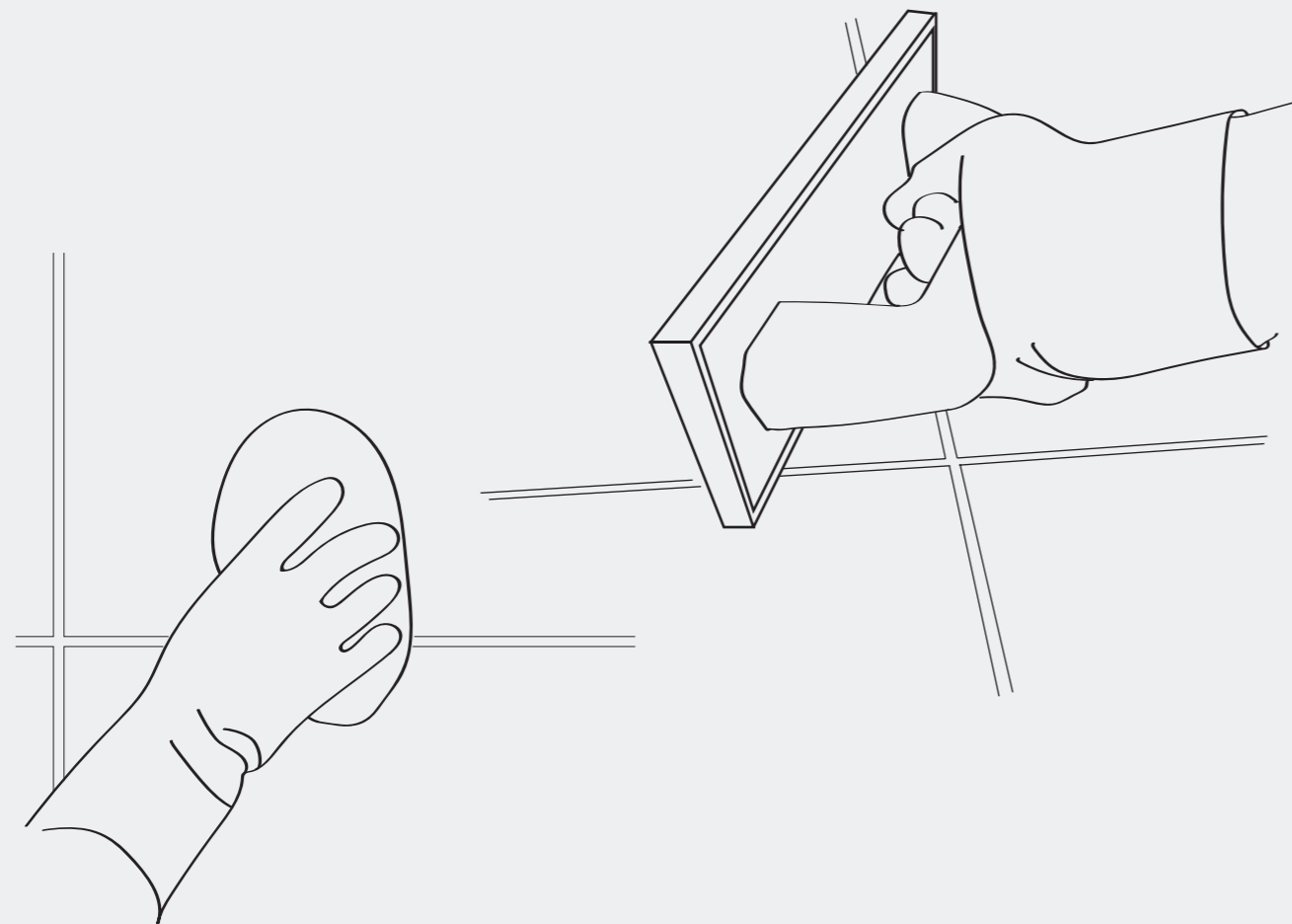

Cement-based grouting products

Recommended for most applications. Grouting that is high-performance, anti-mould, anti-fluorescence, quick fix and dry, water-repellant, class CG2 as per EN 13888 is recommended.

Application

Before applying the grouting, dampen the surface around the joint with a wet cloth or a sponge using a minimal quantity of water so the joints remain dry. Then, completely fill the joints without leaving any gaps using a 45° trowel. Remove any excess grout from the tile surface.

Cleaning

Begin cleaning as soon as the grout begins hardening (generally 10-30 minutes). Do not let any grout remain on the tile surface for much time before completing the initial cleaning.

Use the lowest quantity of water possible to clean the grout from the surface. Any excess water will discolour the joints.

After cleaning each time, rinse and squeeze the sponge so no excess water remains on the slab surface or in the grouted joint.

Change the rinse water frequently.

Make sure all slabs are well-cleaned before the grout dries.

Clean the surface again around an hour later with a clean rag to remove any remains. If there is still some grout on the slabs because it wasn't cleaned correctly, you can use a cement remover but no earlier than 24 hours after grouting.

Reactive resin grouting products

Application

Apply to dry joints with a rubber trowel, making sure the joints are completely filled.

Remove any excess material with the same trowel diagonally, leaving only a fine film of excess on the piece.

Cleaning

Epoxy grout or reactive resins must be cleaned when wet. Dampen the grouting surface and rub with a sponge rather hard in circular movements to soften the grout film and remove it.

Replace the sponge when very impregnated with resin. This is important because hardened grout remains are difficult to remove.

You can do a final cleaning with special cleaners for epoxy grout even several hours after application.

8 BONDING PRIMER

These are products that enhance the adherence between the adhesive and the support or piece for better adherence results than theoretical results simply with adhesive.

Apply the bonding bridge directly on the back of the ASCALE piece in a fine film, preferably using a sponge roller in one direction and repeating the operation by crossing back over. Wait for the product to dry completely before continuing to install the piece.



9 ADHESIVES

Adhesive manufacturers recommend different products based on the type of application and environment.

For more information on adequate adhesives for each use, ask your sales representative or your adhesive supplier.

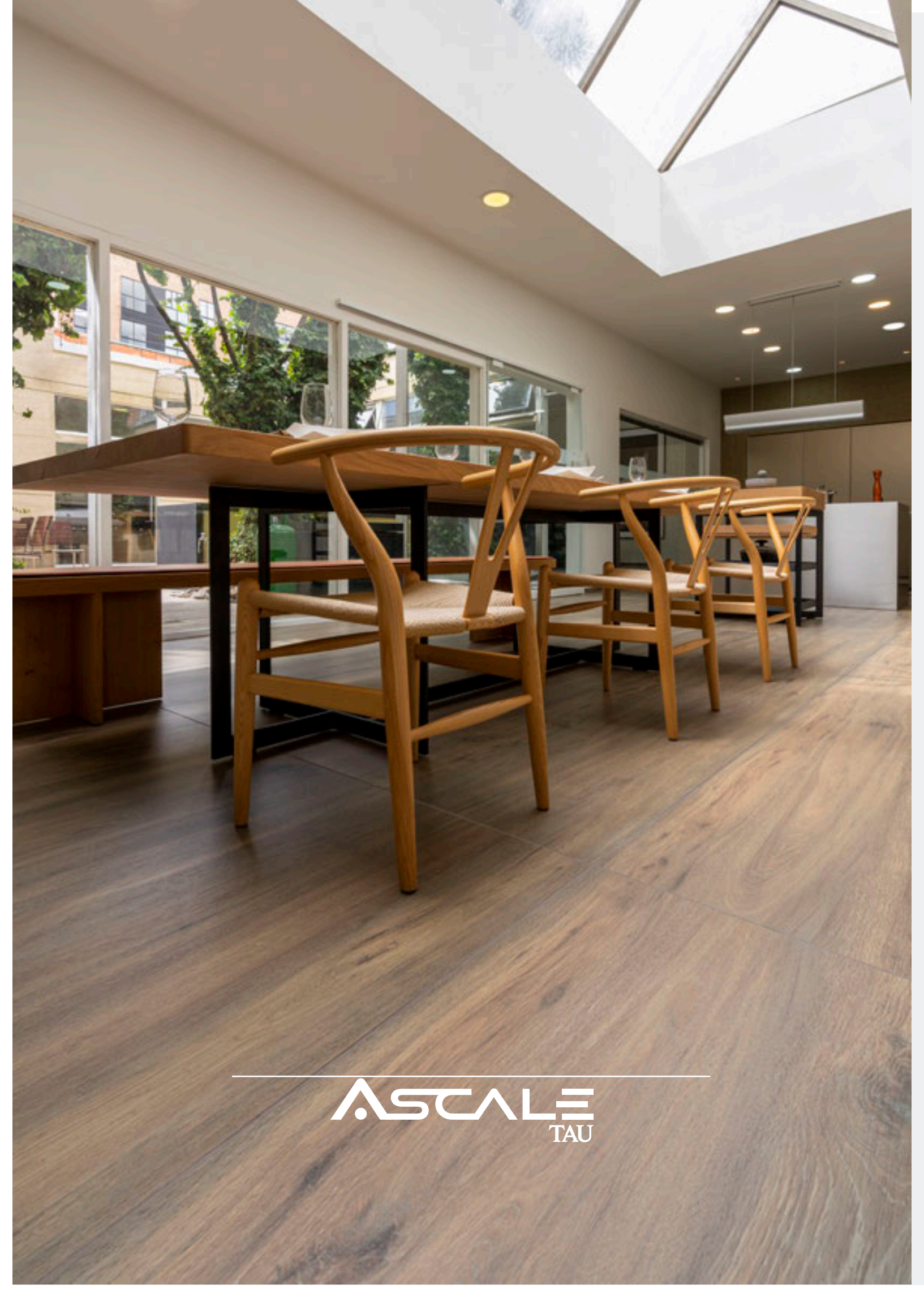

ASTALE
TAU